

X-Ray Production

The components of an X-ray tube

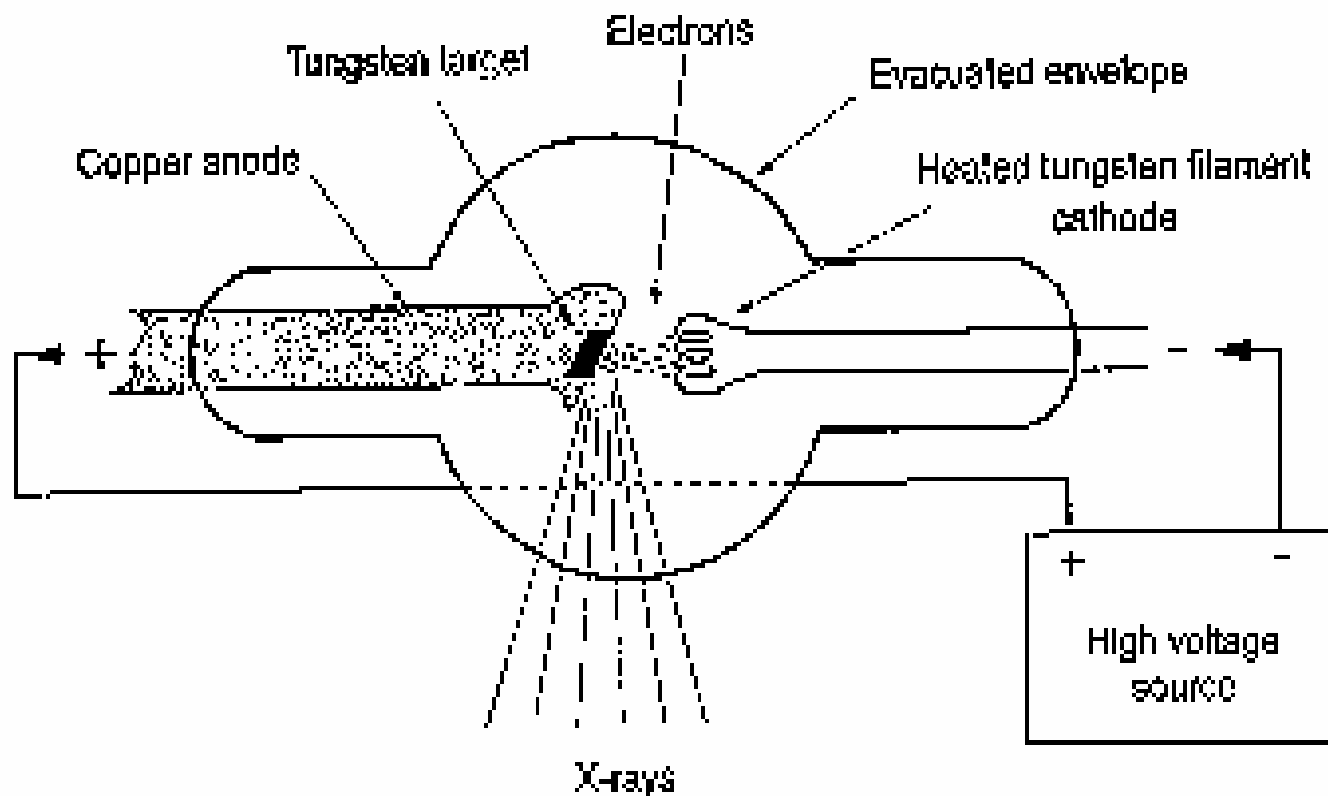

Figure 4.1. X-ray production requirements include a source and target of electrons, evacuated envelope, and high-voltage source.

High energy electron beam striking high-Z material

Electron Beam



High-Z Material

STOPPING POWER

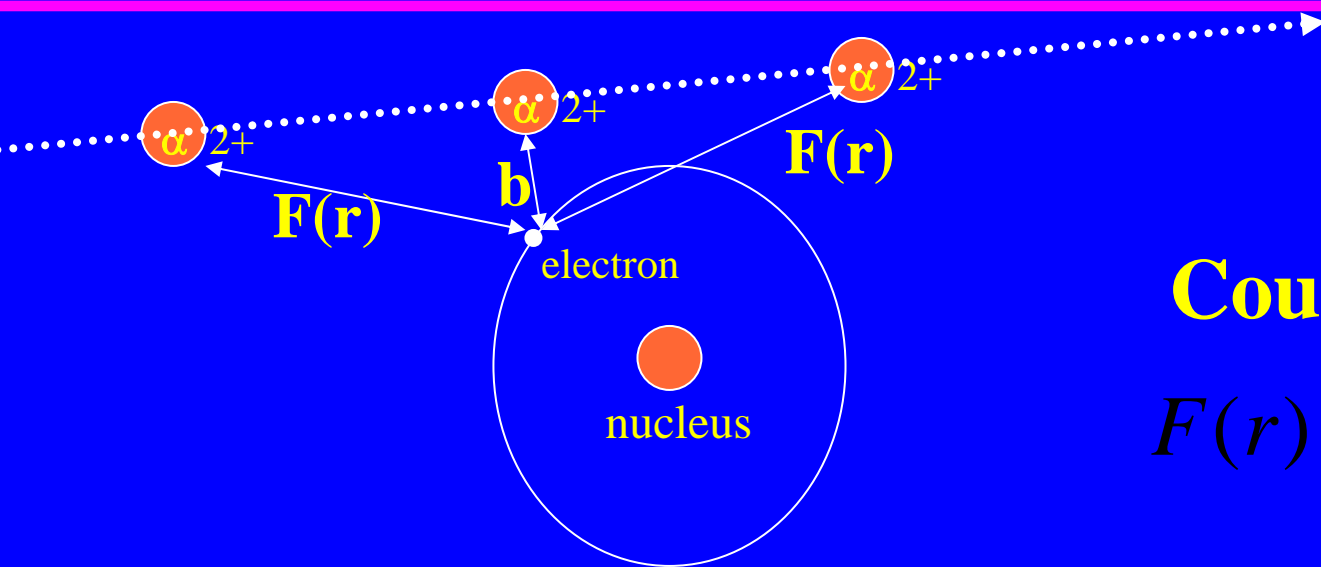

Coulomb force

$$F(r) = \frac{q * Q}{r * r}$$

$$\text{Momentum} = \int F dt = \frac{2ze^2}{bv}$$

$$\text{Energy} = \frac{2ze^4}{mb^2 v^2}$$

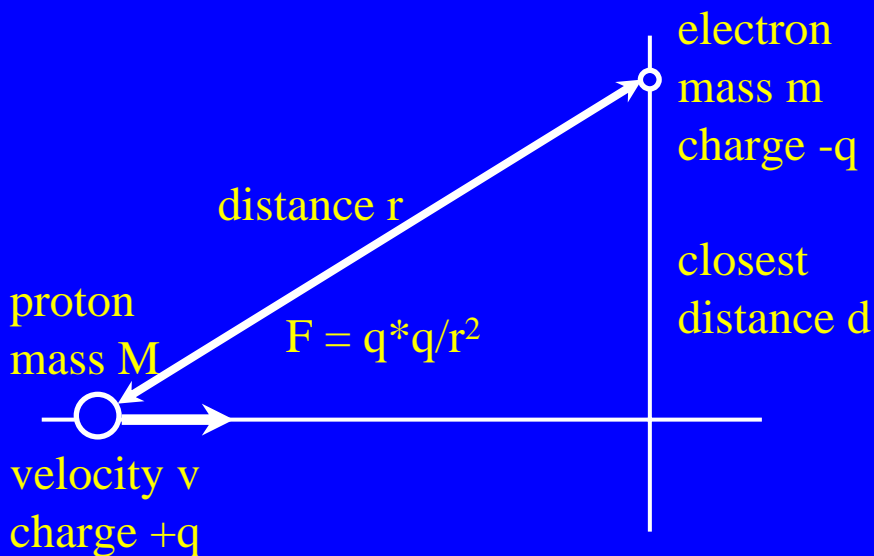

High energy electron beam striking high-Z material produces Heat

Electron Beam



Heat



99% or more of the
electron beam energy
is deposited as heat!

High-Z Material

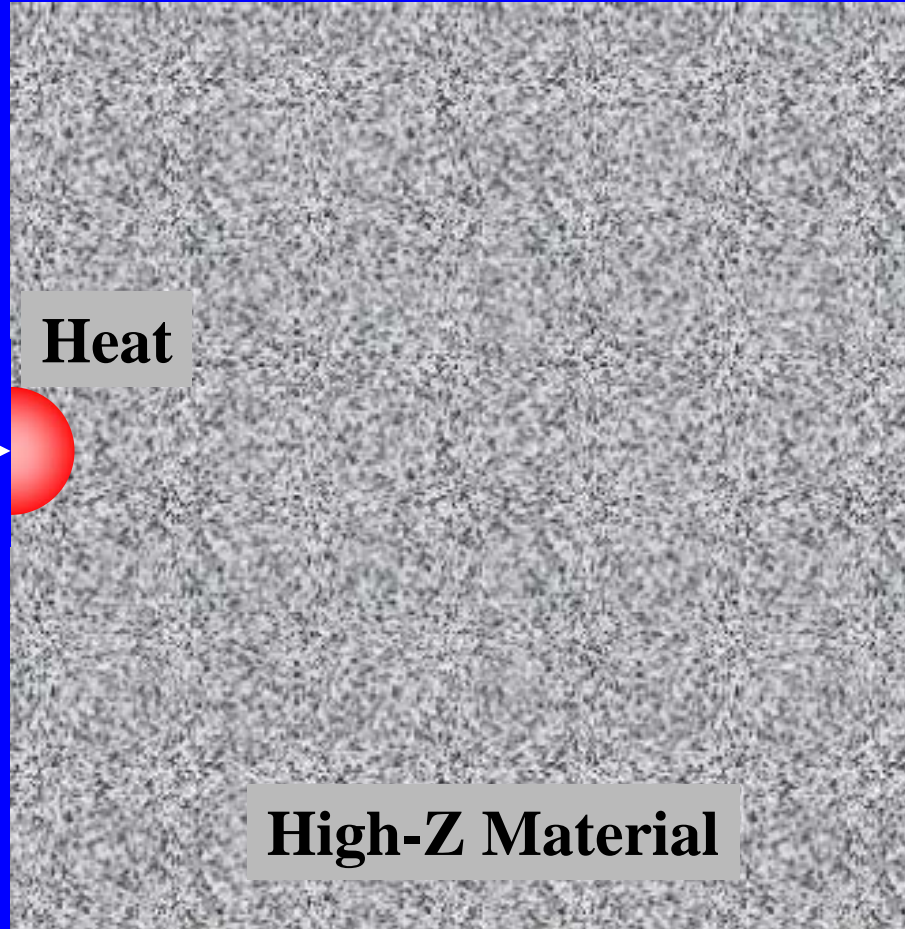

High energy electron beam striking high-Z material produces Heat and X Rays.

Electron Beam



X Rays

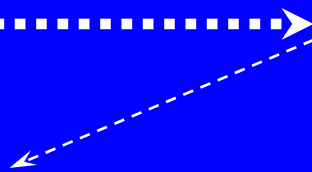

Less than 1% of
electron beam energy!

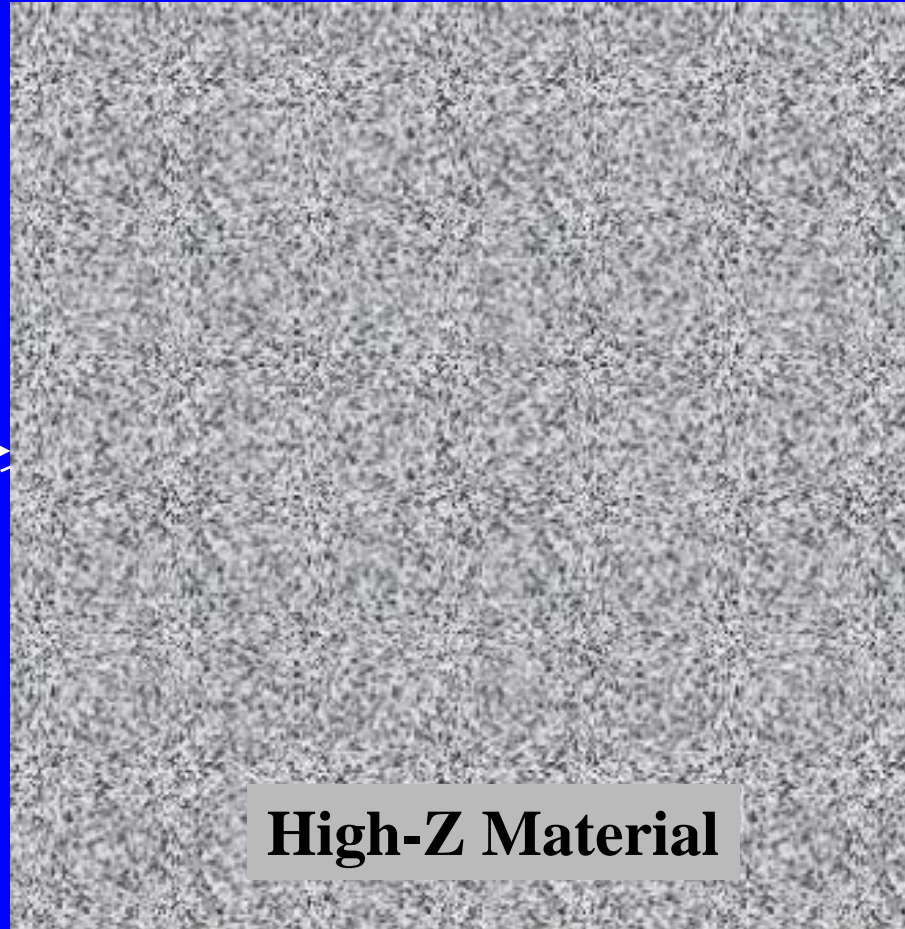

High-Z Material

Creation of bremsstrahlung

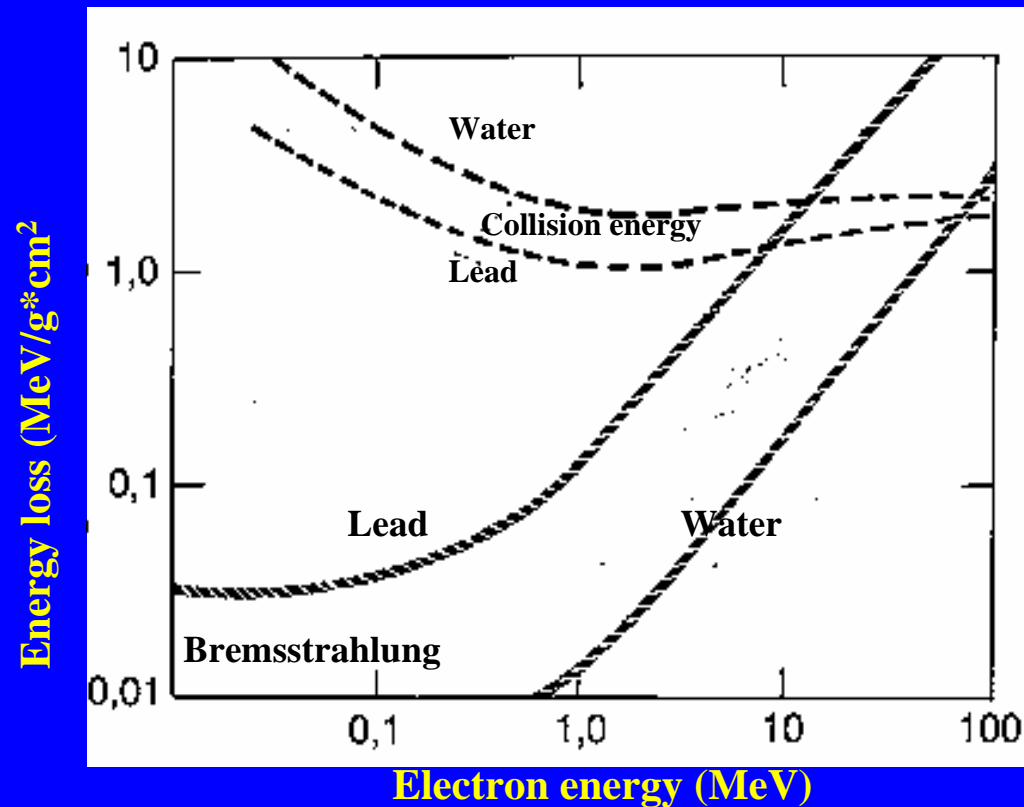
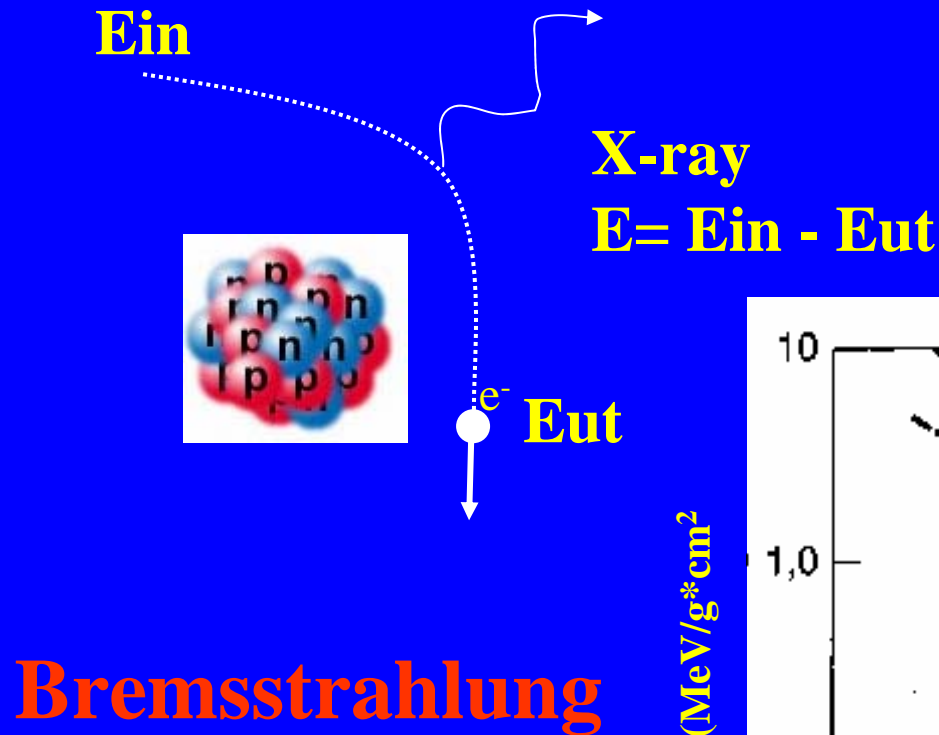

Bremsstrahlung “braking” radiation

Collision with weakly-bound electrons slows electron beam and produces x rays.

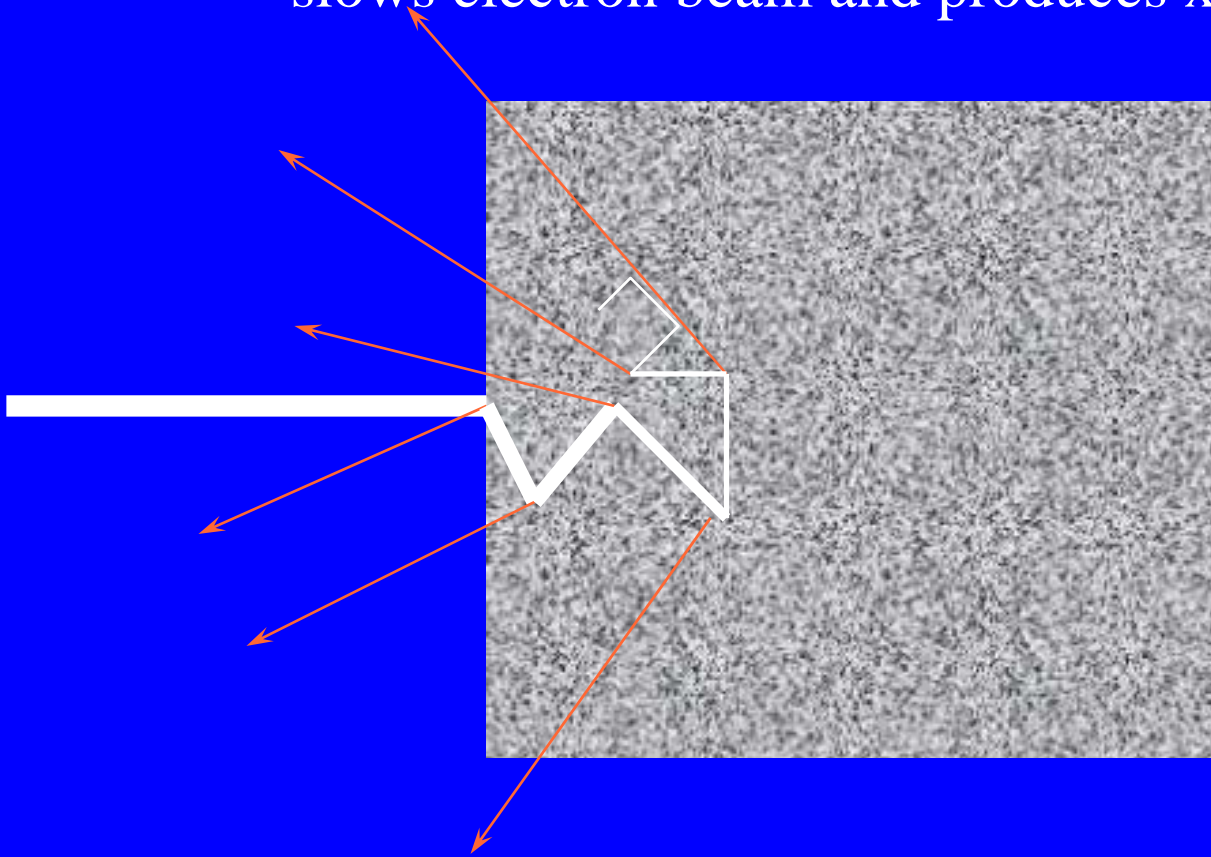

Electron range in a Tungsten anode

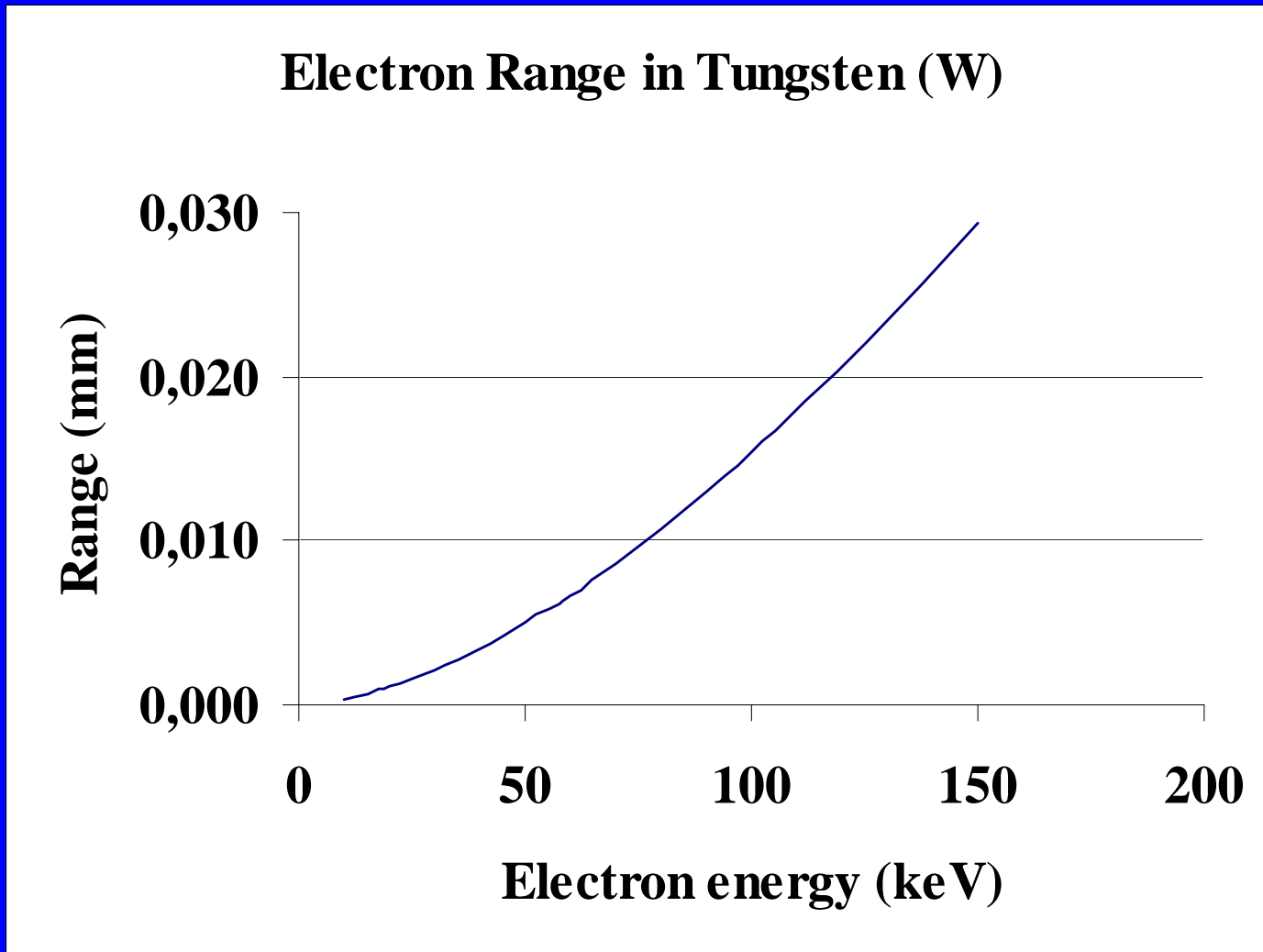

Energy of x rays is function of electron beam energy, E_{\max}

Low energy x rays are absorbed in target.

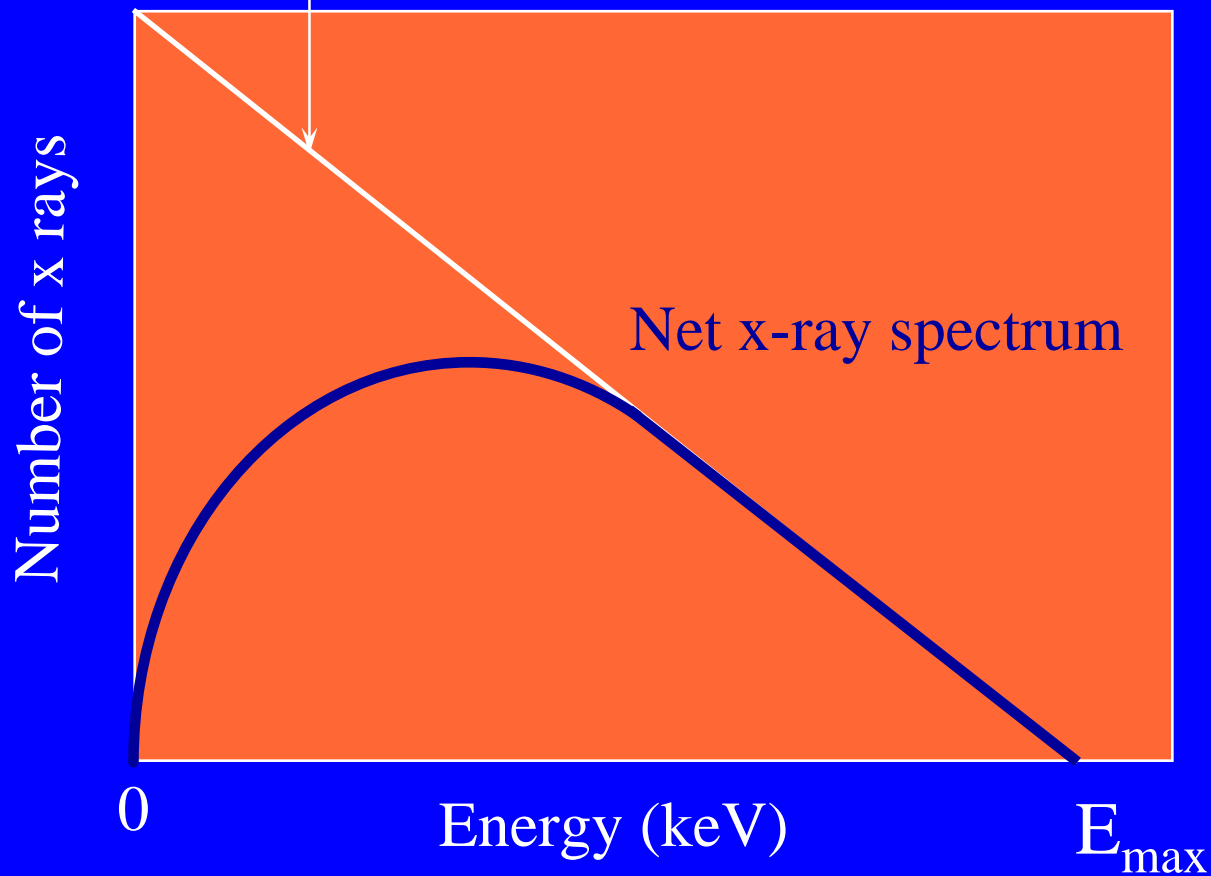

Bremsstrahlung x-ray properties

- ◆ electron beam interaction with loosely-bound electrons
- ◆ electron loses energy with successive e^- collisions
- ◆ continuous spectrum of x-ray energies
- ◆ highest x-ray energy = E_{electron}
- ◆ Interaction proportional to Z
- ◆ Interaction proportional to E_{electron}^2

Characteristic x rays produced by photo-electric absorption of tightly-bound electrons

electron ($E > BE_K$)

K-shell electron ejected

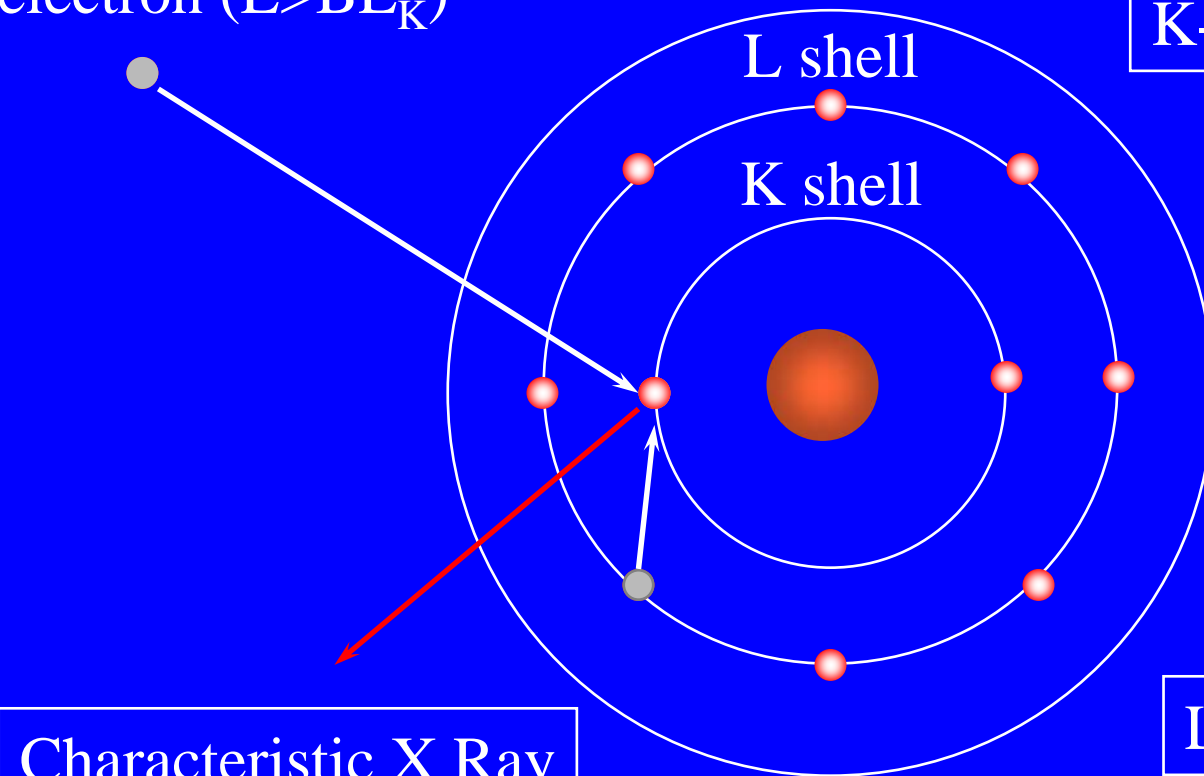

Characteristic X Ray

L electron fills K shell

Characteristic x-ray energies

- ◆ electron beam interaction with tightly-bound electrons
- ◆ K shell most important
- ◆ $E_{\text{electron}} > BE_{\text{K}}$
- ◆ discrete x-ray energies emitted
- ◆ x-ray energies = difference in BE
- ◆ maximum x-ray energy = $BE_{\text{K}} - BE_{\text{L}} < BE_{\text{K}}$
- ◆ BE_{K} proportional to Z^2

Typical x-ray spectrum

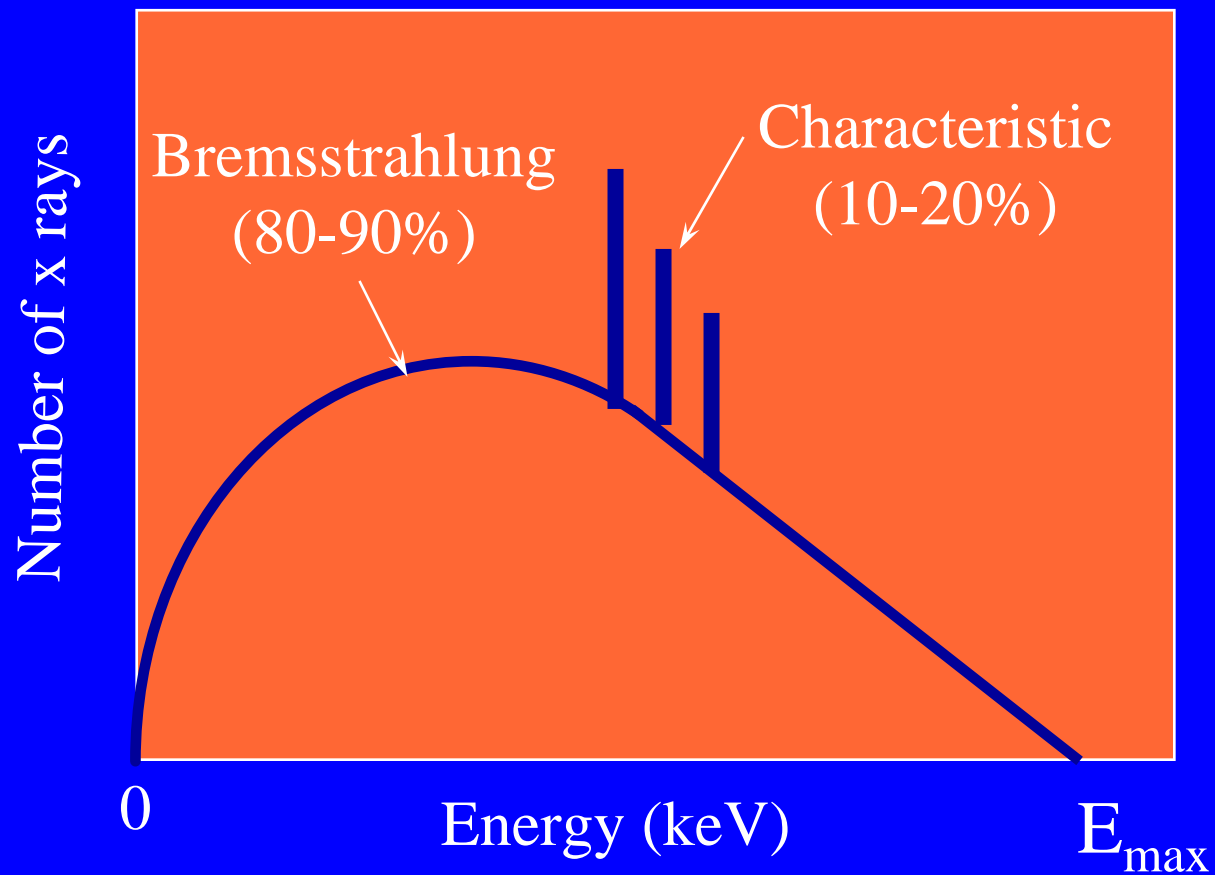

Fixed contra rotating anode

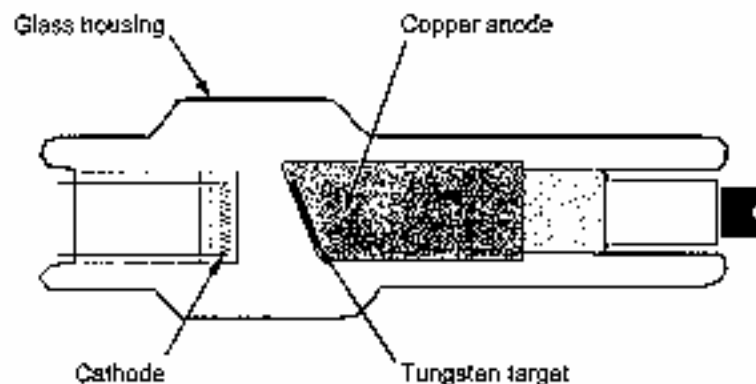

Figure 4.10. The fixed anode x-ray tube is comprised of a tungsten insert placed in a copper block. Heat is removed (dissipated) from the target area by conduction into the copper block.

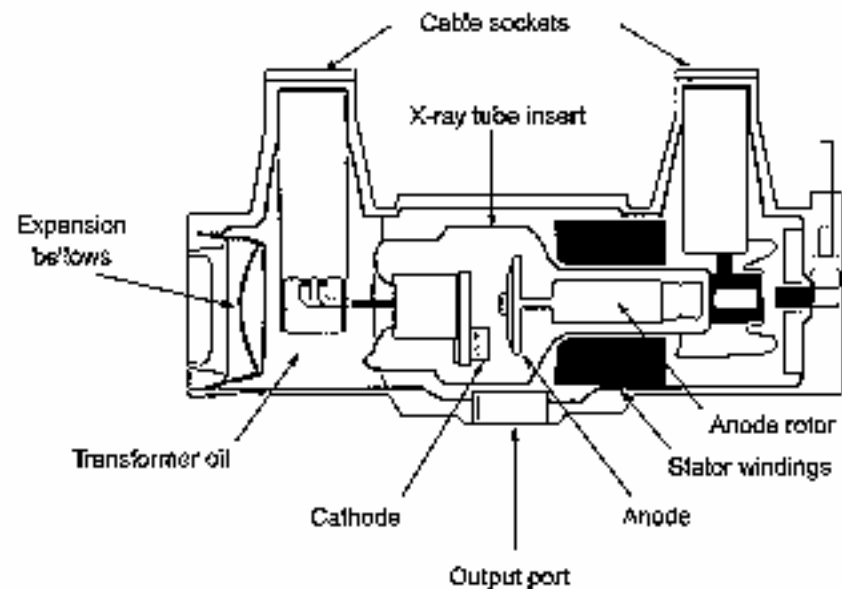
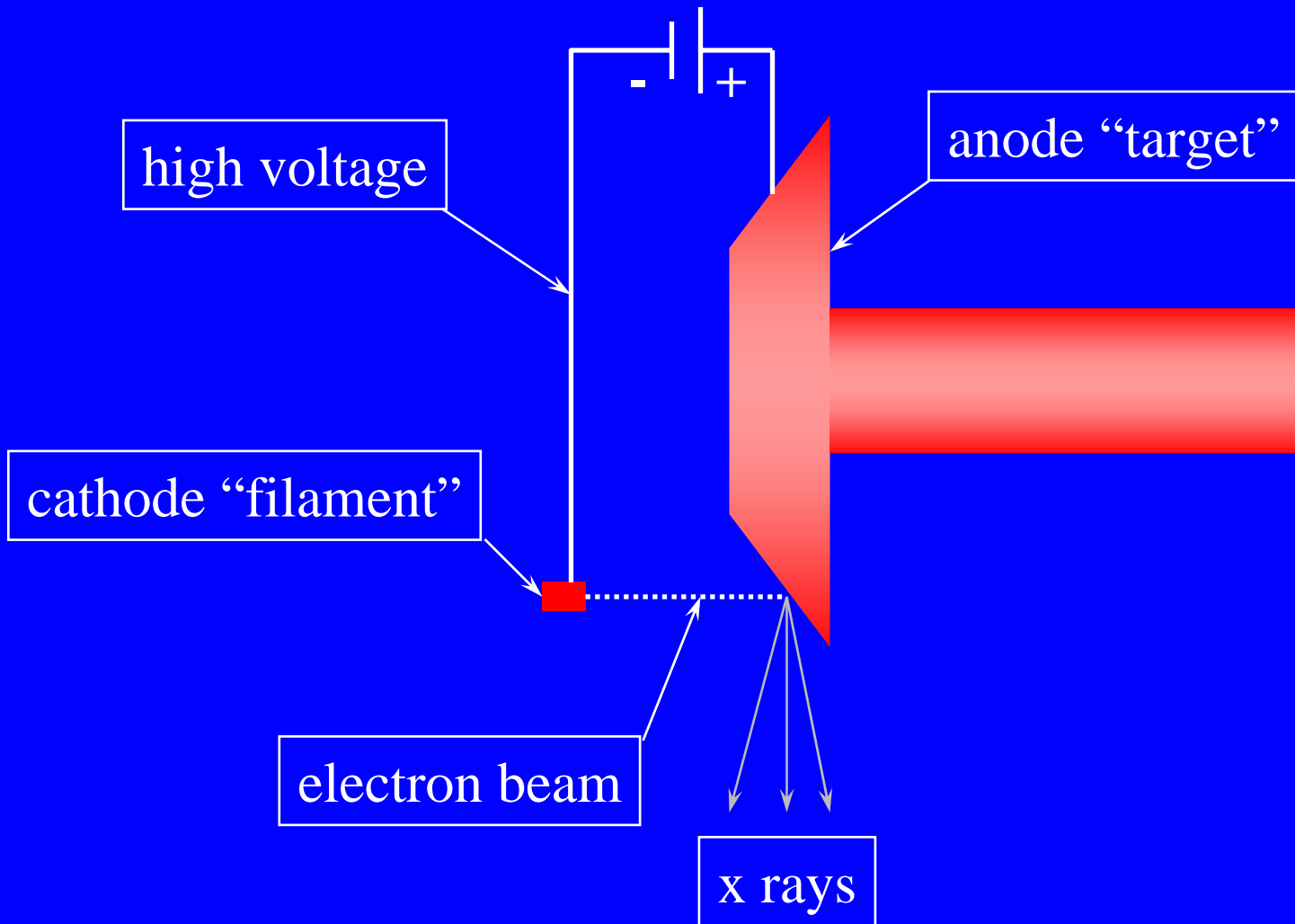
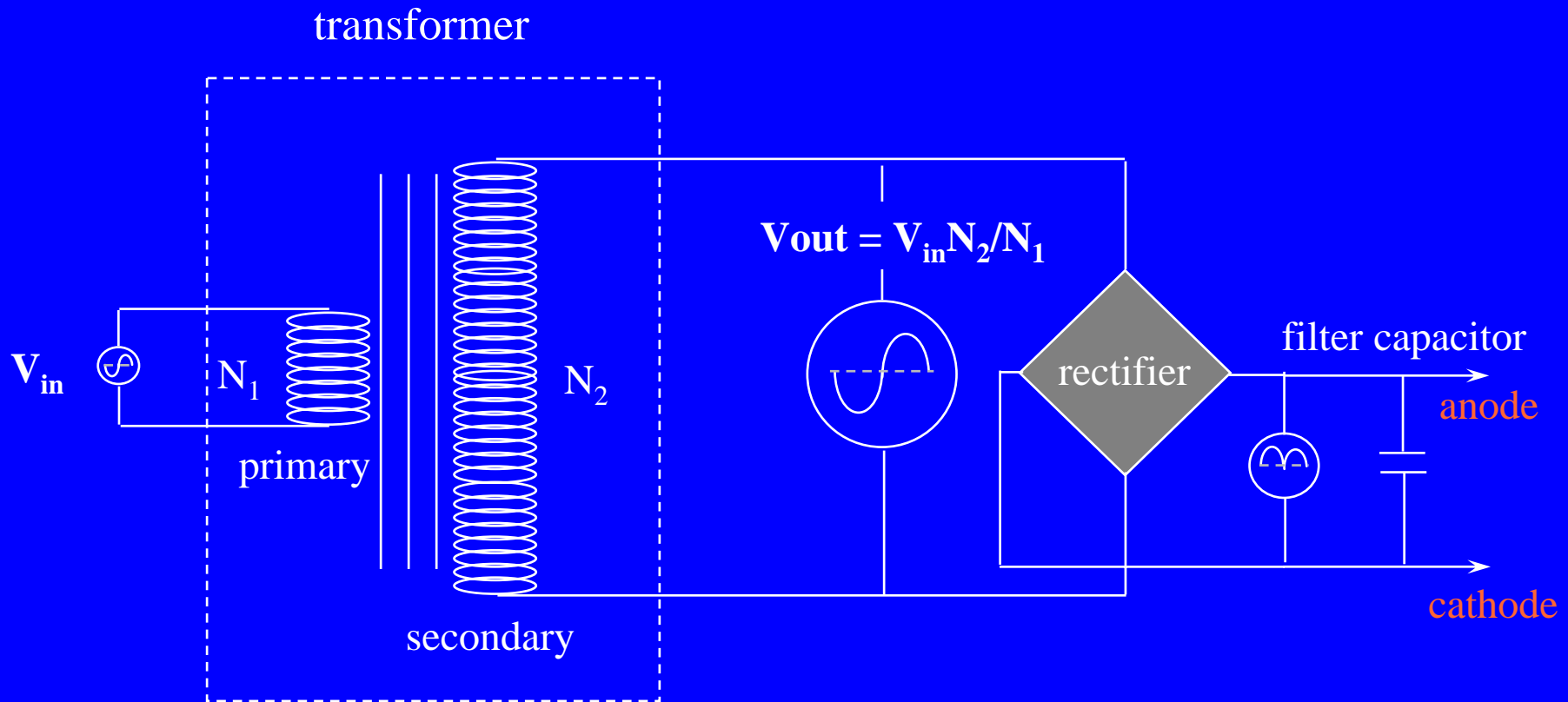

Figure 4.6. A modern x-ray tube and housing assembly.

X ray tube design



High voltage generation



Types of rectification

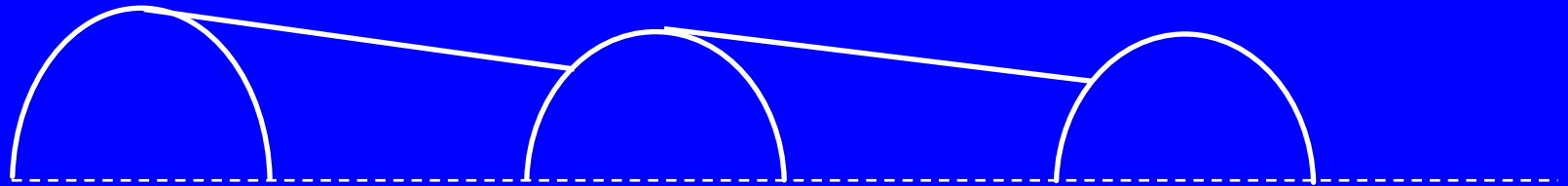
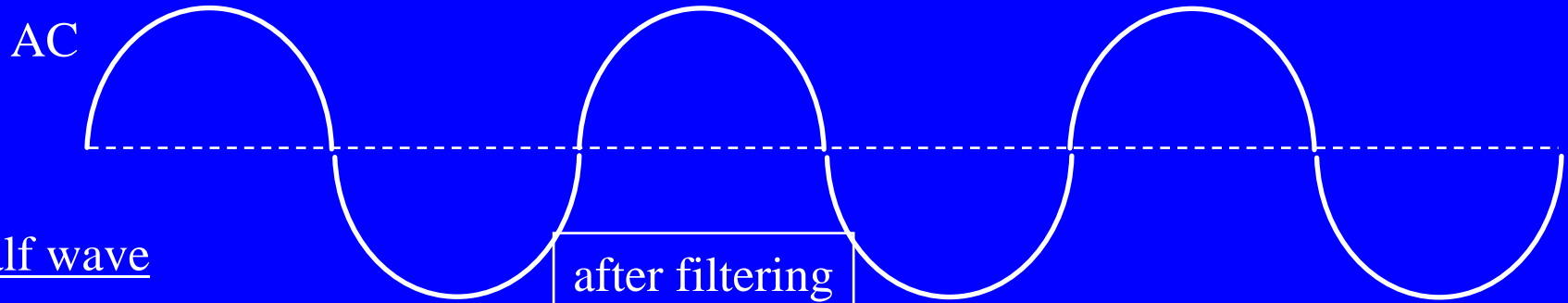

full wave

after filtering

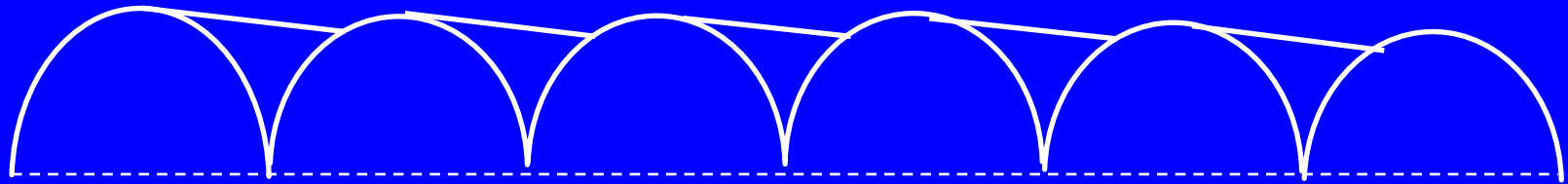

Three phase versus single phase

single phase

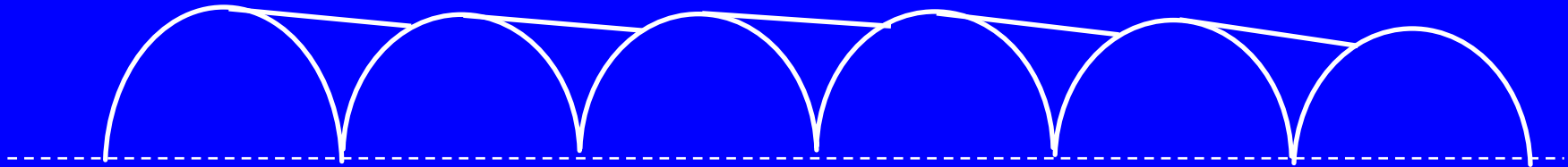

three phase

after filtration

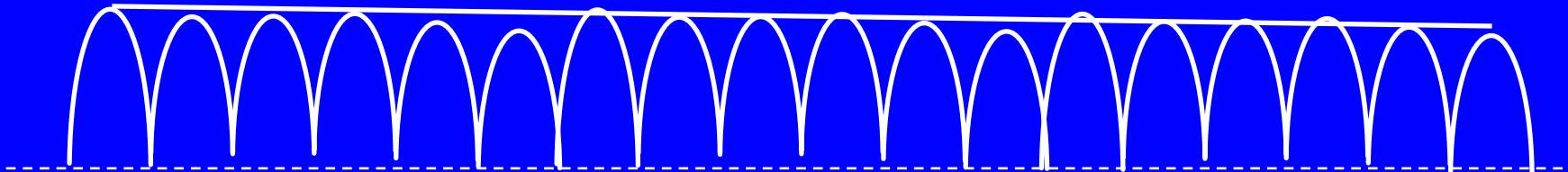

High voltage ripple decreases spectrum energy

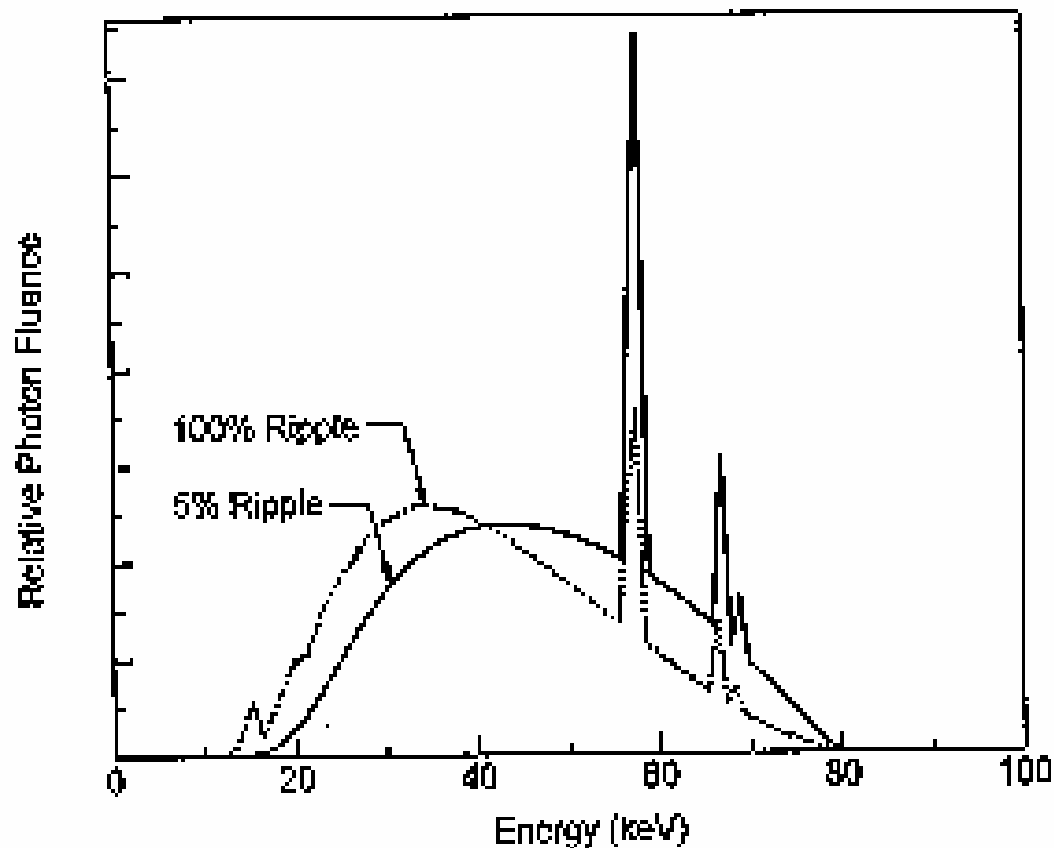

Figure 4.29. Output intensity (bremsstrahlung) spectra of a single-phase (100% ripple) versus a 3-phase generator (5% ripple at 60 kVp) for a given kVp and mA/s demonstrate the higher effective energy and greater output of the low-voltage ripple 3-phase generator.

High voltage generator properties

- ◆ full-wave rectification better than half-wave
- ◆ three phase better than single phase
- ◆ twelve-pulse, full-wave better than six-pulse, full wave

HV generator controls

- ◆ peak kilovoltage (kVp)
- ◆ tube current (mA)
- ◆ exposure time (s)
- ◆ total **energy** delivered to tube:
$$\text{Energy} = \text{kVp} * \text{mA} * \text{s} = \text{kVp} * \text{mAs}$$
- ◆ instantaneous **power** delivered to tube:
$$\text{Power} = \text{kVp} * \text{mA}$$
- ◆ x-ray tube limited in both power and energy

Focal spot geometry

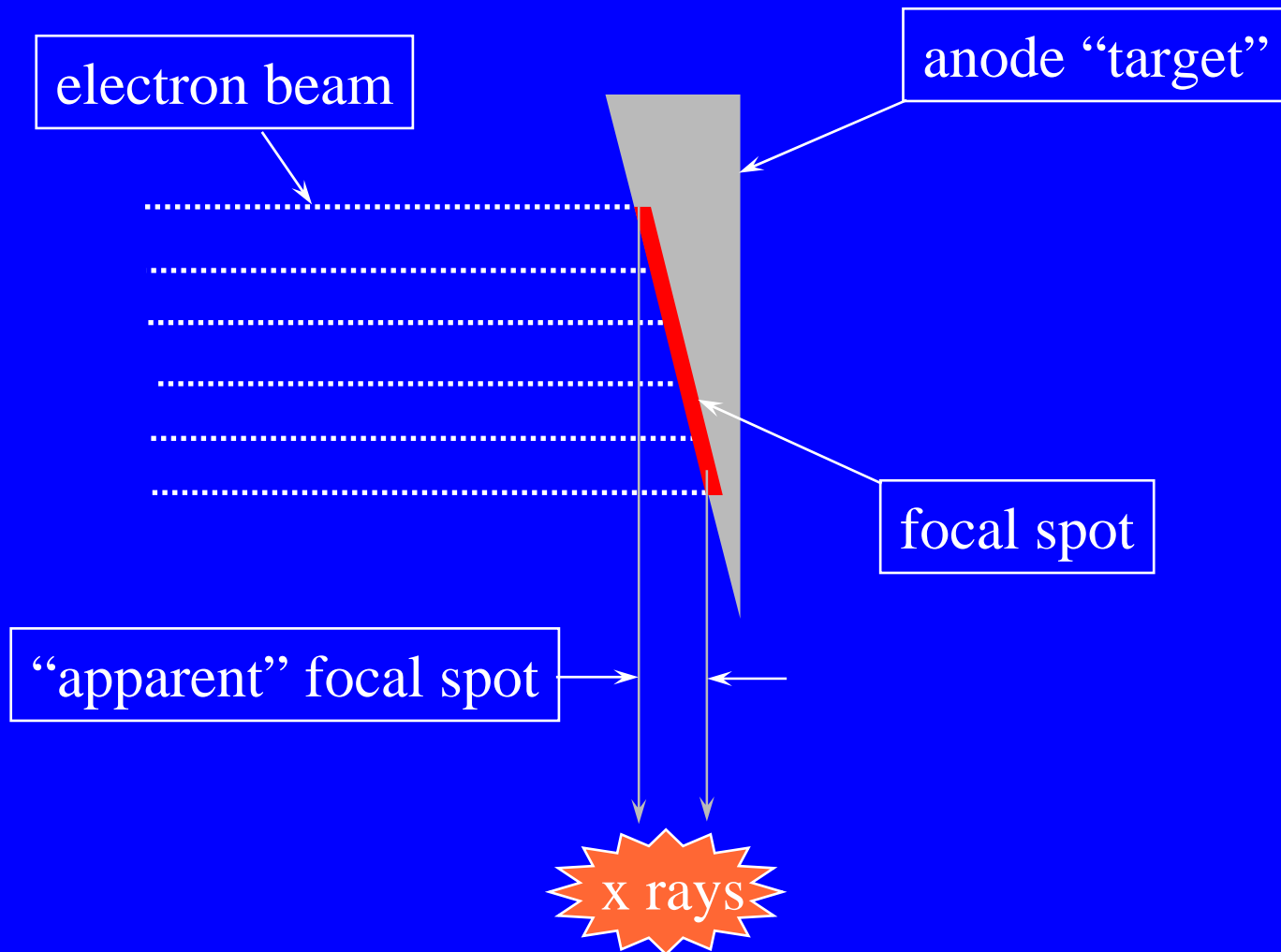

Focusing the electron beam increase resolution

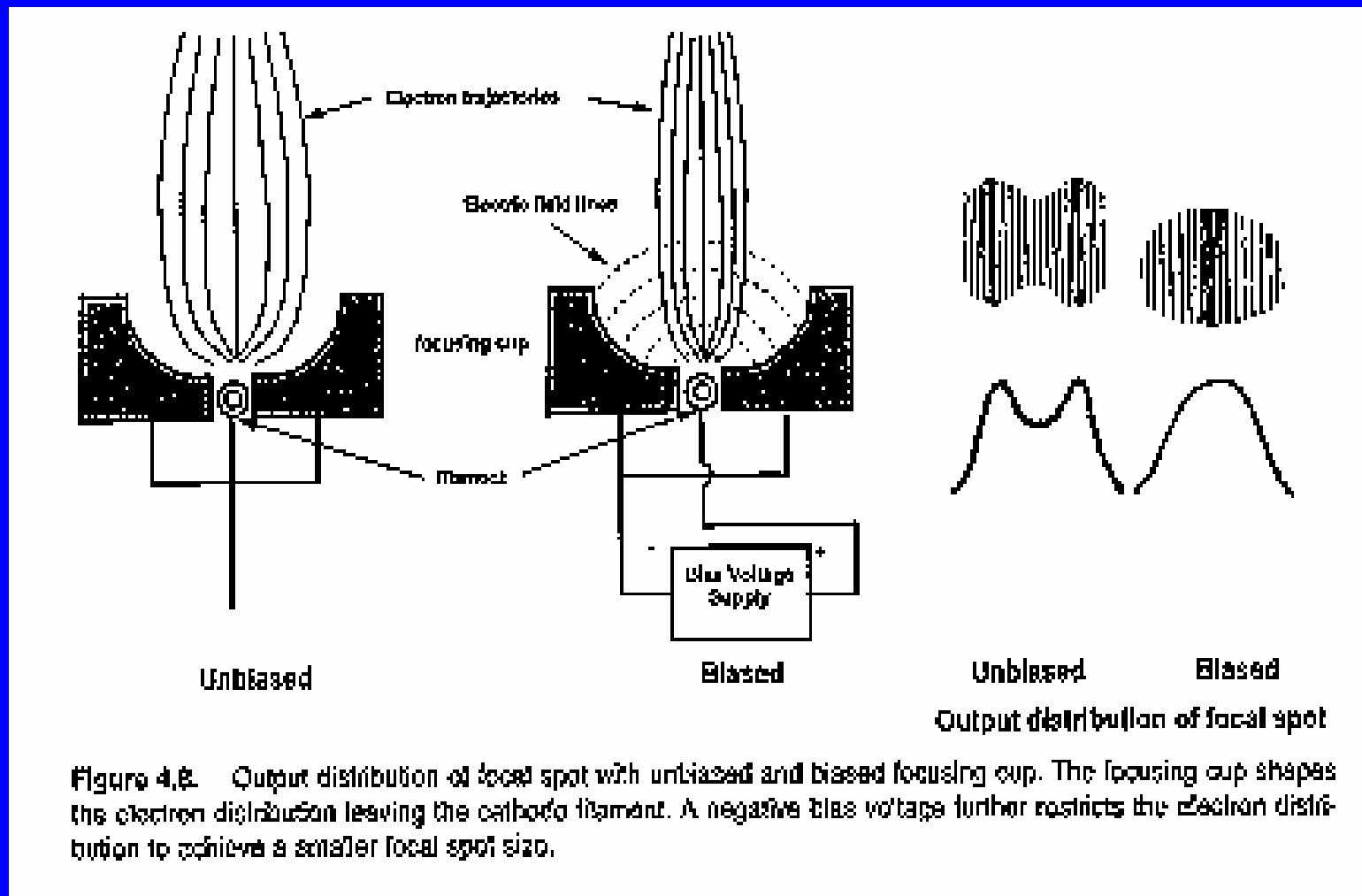

Anode angle relates to beam width

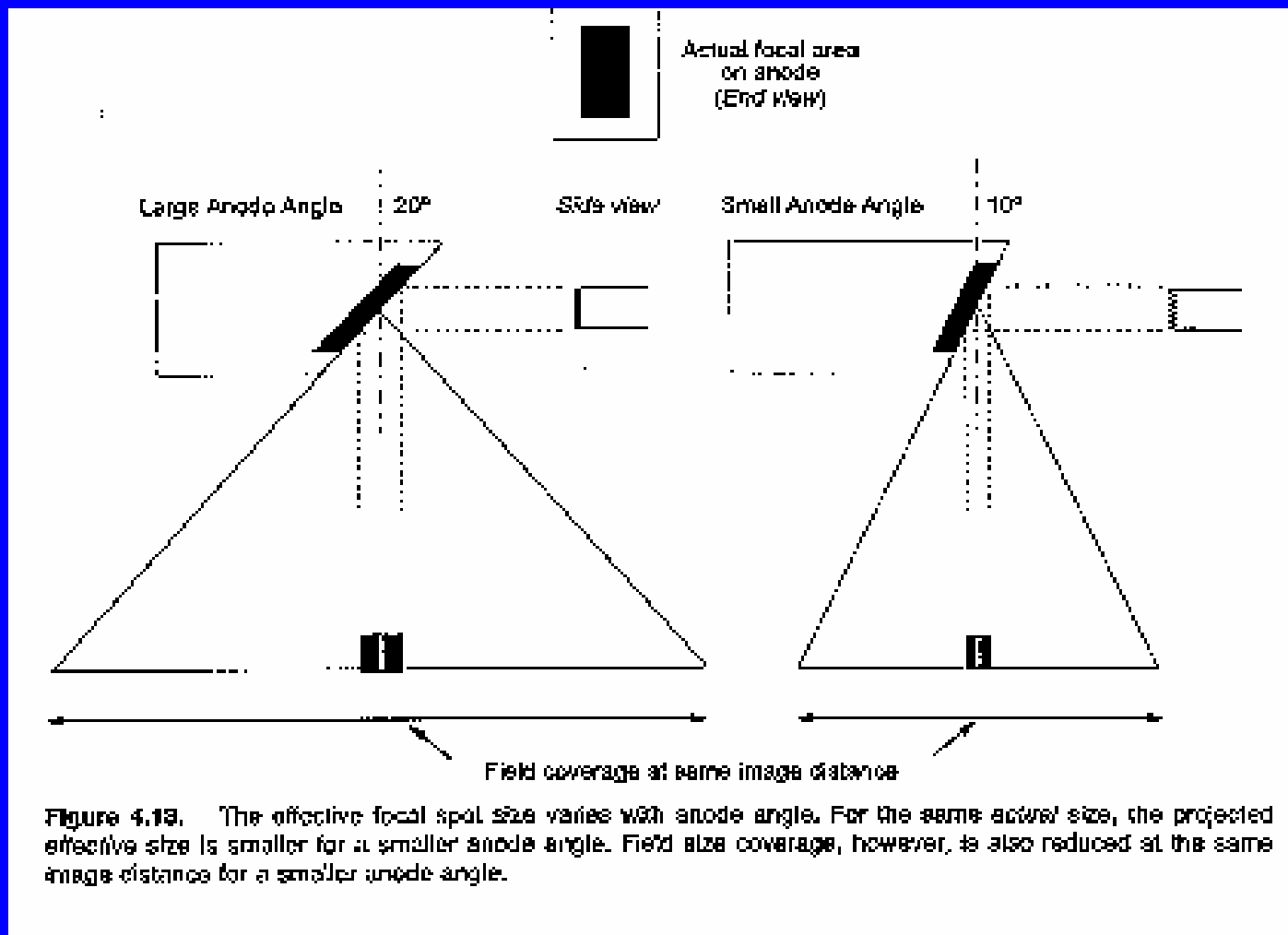

Heal effect

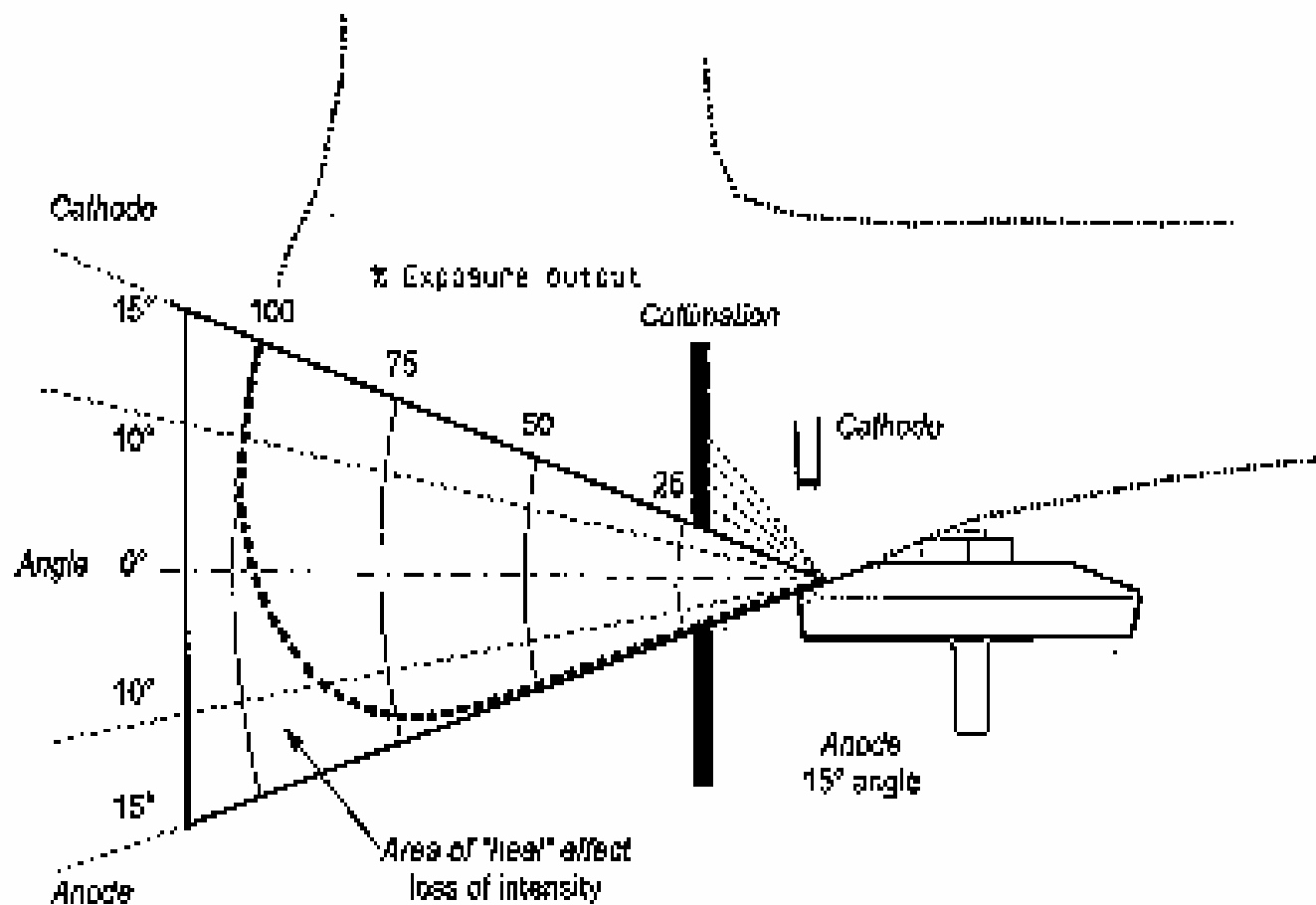
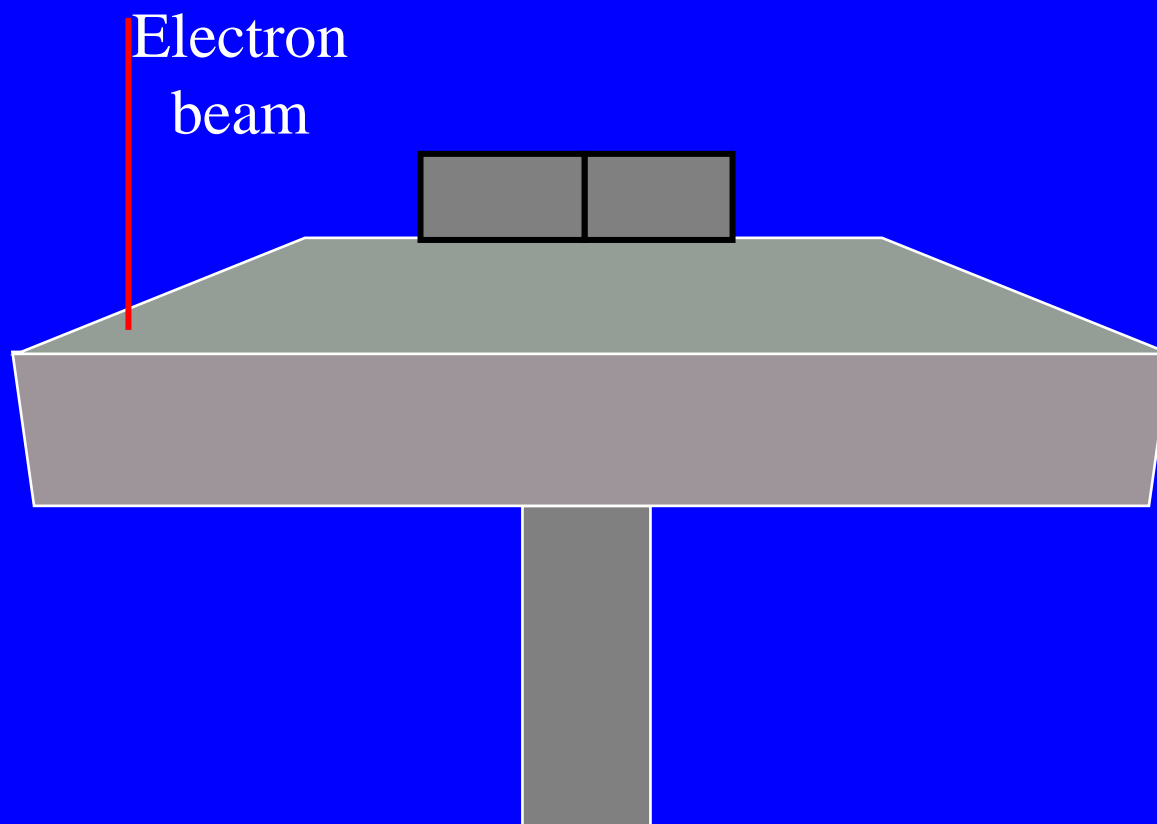
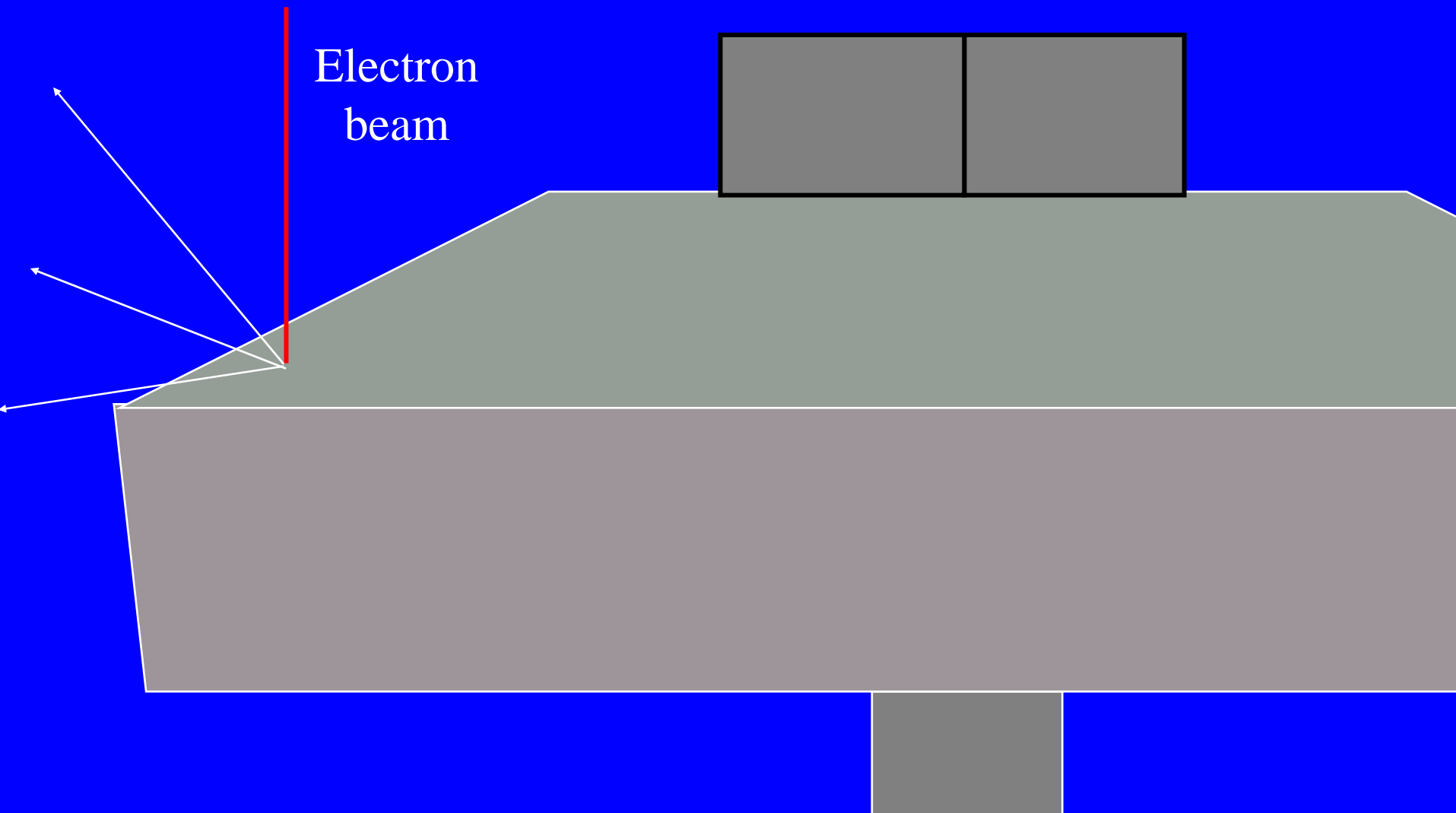

Figure 4.15. The "heel" effect is a loss of intensity on the anode side of the x-ray tube. This figure illustrates the origin of its name.

Heal effect



Heal effect



Angulated focal spot properties

- ◆ “target” angulated 10° - 20°
- ◆ “apparent” focal spot foreshortened
- ◆ heat spread out over larger anode area
- ◆ “apparent” focal spot increases in size toward cathode
- ◆ “apparent” focal spot decreases in intensity toward anode - “heel” effect